

# XCalibur1501

Freescale MPC8572E Processor-Based Conduction- or Air-Cooled 6U cPCI Module

- ▶ Freescale MPC8572E PowerQUICC™ III processor with dual PowerPC e500 cores at up to 1.5 GHz
- ▶ Conduction or air cooling
- ▶ Two channels of up to 4 GB (2 GB each) DDR2-800 ECC SDRAM
- ▶ Up to 256 MB of NOR flash (with redundancy)
- ▶ Up to 4 GB of NAND flash
- ▶ Four Gigabit Ethernet ports
- ▶ x8 PCI Express to XMC sites
- ▶ Two SATA 3.0 ports to J5
- ▶ Three USB 2.0 ports (one configurable to front panel and two to J5)
- ▶ Two RS-232/RS-422/RS-485 serial ports
- ▶ Two PrPMC/XMC interfaces
- ▶ Linux BSP
- ▶ Wind River VxWorks BSP
- ▶ QNX Neutrino BSP
- ▶ Green Hills INTEGRITY BSP

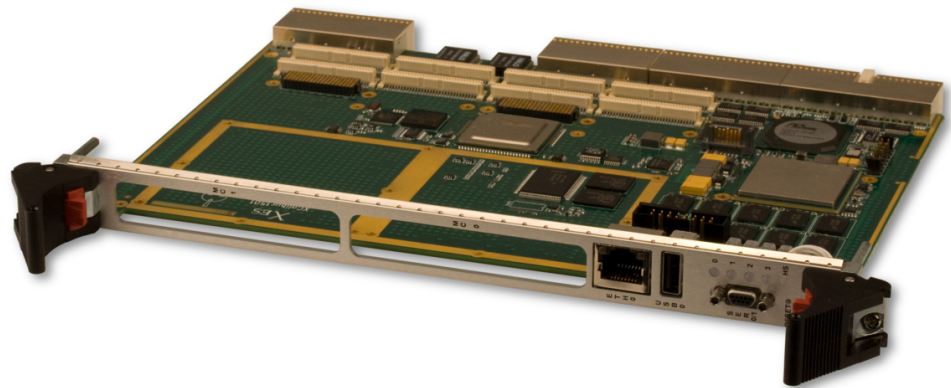

## XCalibur1501

The XCalibur1501 is a high-performance 6U CompactPCI single board, multiprocessing computer that is ideal for ruggedized systems requiring high bandwidth processing and low power consumption. With dual PowerPC e500 cores running at up to 1.5 GHz, the MPC8572E delivers enhanced performance and efficiency for today's XCalibur1501s embedded computing applications.

The XCalibur1501 provides two separate channels of up to 4 GB (2 GB each) DDR2-800 ECC SDRAM, two PrPMC/XMC slots, as well as 256 MB of NOR flash (with redundancy). The XCalibur1501 also supports four Gigabit Ethernet ports, I<sup>2</sup>C, PMC I/O, XMC I/O, and RS-232/RS-422/RS-485 serial ports out the front panel or J5 connector.

The XCalibur1501 is a powerful, feature-rich solution for the next generation of compute intensive embedded applications. Operating system support for Wind River VxWorks, Green Hills INTEGRITY, QNX Neutrino, and Linux are available.

# X-ES

Extreme Engineering Solutions

*...Always Fast*

### Extreme Engineering Solutions

3225 Deming Way, Suite 120 • Middleton, WI 53562  
 Phone: 608.833.1155 • Fax: 608.827.6171  
 sales@xes-inc.com • <http://www.xes-inc.com>

**Processing Nodes**

- Freescale MPC8572E PowerQUICC III processor
- Dual PowerPC e500 cores at up to 1.5 GHz
- 1 MB of shared L2 cache

**Memory**

- Two channels of DDR2 ECC SDRAM, up to 4 GB (2 GB each)
- Up to 4 GB of NAND flash
- Up to 256 MB of NOR flash (with redundancy)
- 16 kB I<sup>2</sup>C SEEPRM
- Trusted Platform Module (optional)

**cPCI**

- 66 MHz 64-bit PCI interface to J1 and J2
- PICMG 2.1 (hot swap support)
- PICMG 2.3 (PMC I/O to J3 and J5)
- PICMG 2.9 (dedicated IPMI controller)
- PICMG 2.16 (two 10/100/1000BASE-T Ethernet ports)

**Front Panel**

- Two RS-232 serial ports
- One or two Gigabit Ethernet ports
- One USB 2.0 port
- General purpose LEDs

**Back Panel**

- Two RS-232/RS-485 serial ports
- Two Gigabit Ethernet ports
- Two SATA ports
- PMC I/O
- Two USB 2.0 ports

**Software Support**

- Linux BSP
- Wind River VxWorks BSP
- QNX Neutrino BSP
- Greens Hills INTEGRITY BSP

**Environmental Requirements**

Contact factory for appropriate board configuration based on environmental requirements.

- Supported ruggedization levels (see chart below): 1, 3, 5
- Conformal coating available as an ordering option

**Power Requirements**

Tested with MPC8572E at 105°C

- 36 W (est.) per board

Supported Ruggedization Level	Level 1	Level 3	Level 5
Cooling Method	Standard Air-Cooled	Rugged Air-Cooled	Conduction-Cooled
Operating Temperature	0 to +55 °C ambient (300 LFM)	-40 to +70 °C (600 LFM)	-40 to +85 °C (board rail surface)
Storage Temperature	0 to +85 °C ambient	-40 to +105 °C ambient	-55 to +105 °C ambient
Vibration	0.002 g <sup>2</sup> /Hz, 5 to 2000 Hz	0.04 g <sup>2</sup> /Hz (maximum), 5 to 2000 Hz	0.1 g <sup>2</sup> /Hz (maximum), 5 to 2000 Hz
Shock	20 g, 11 ms sawtooth	30 g, 11 ms sawtooth	40 g, 11 ms sawtooth
Humidity	0% to 95% non-condensing	0% to 95% non-condensing	0% to 95% non-condensing

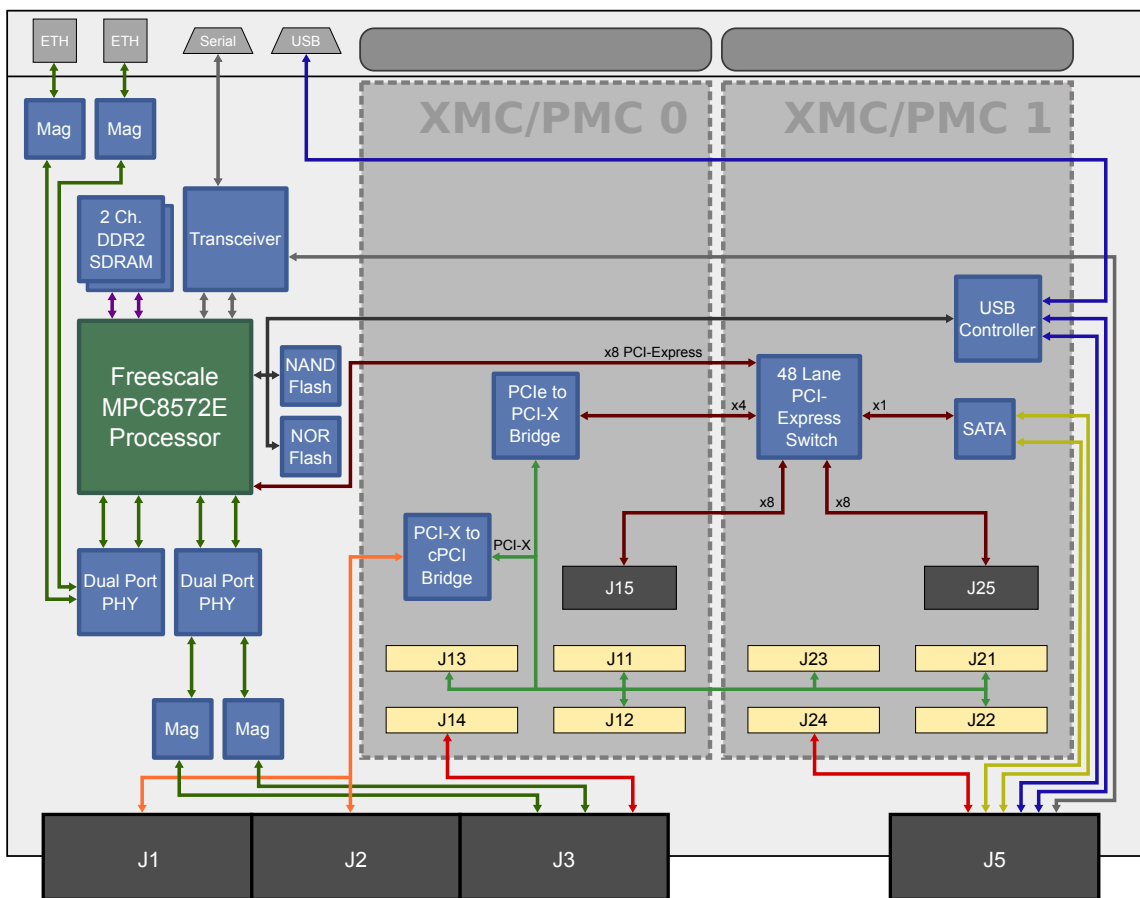

XCalibur1501

