

XCalibur1501

End of Life

Freescale MPC8572E Processor-Based Conduction- or Air-Cooled 6U cPCI Module

Please contact X-ES Sales

- ▶ Freescale MPC8572E PowerQUICC™ III processor with dual PowerPC e500 cores at up to 1.5 GHz
- ▶ Conduction or air cooling
- ▶ Up to 4 GB DDR2-800 ECC SDRAM in two channels
- ▶ Up to 4 GB of NAND flash
- ▶ Up to 256 MB of NOR flash (with redundancy)
- ▶ Four Gigabit Ethernet ports
- ▶ x8 PCI Express to XMC sites
- ▶ Two RS-232/422/485 serial ports
- ▶ Two XMC/PrPMC interfaces
- ▶ Linux BSP
- ▶ Wind River VxWorks BSP
- ▶ Green Hills INTEGRITY BSP
- ▶ QNX Neutrino BSP (contact factory)

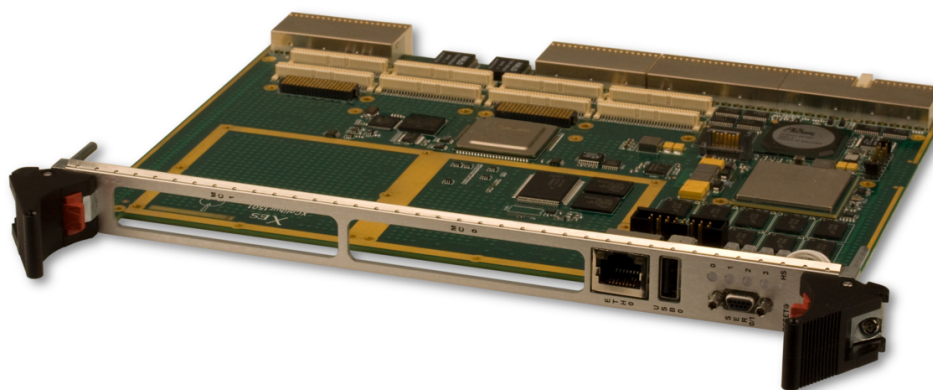

XCalibur1501

The XCalibur1501 is a high-performance, multiprocessing, 6U CompactPCI, single board computer that is ideal for ruggedized systems requiring high bandwidth processing and low power consumption. With dual PowerPC e500 cores running at up to 1.5 GHz, the MPC8572E delivers enhanced performance and efficiency for today's embedded computing applications.

The XCalibur1501 provides two separate channels of up to 4 GB (2 GB each) DDR2-800 ECC SDRAM, two PrPMC/XMC slots, as well as 256 MB of NOR flash (with redundancy). The XCalibur1501 also supports four Gigabit Ethernet ports, I²C, XMC I/O, PMC I/O, and RS-232/422/485 serial ports out the front panel or J5 connector.

The XCalibur1501 is a powerful, feature-rich solution for the next generation of compute-intensive embedded applications. Operating system support for Wind River VxWorks, Green Hills INTEGRITY, QNX Neutrino, and Linux is available.

X-ES

Extreme Engineering Solutions

...Always Fast

Extreme Engineering Solutions

3225 Deming Way, Suite 120 • Middleton, WI 53562

Phone: 608.833.1155 • Fax: 608.827.6171

sales@xes-inc.com • <http://www.xes-inc.com>

Processor

- Freescale MPC8572E PowerQUICC™ III processor
- Dual PowerPC e500 cores at up to 1.5 GHz
- 1 MB of shared L2 cache

Memory

- Up to 4 GB (2 GB each) of DDR2 ECC SDRAM in two channels
- Up to 4 GB of NAND flash
- Up to 256 MB of NOR flash (with redundancy)
- 16 kB I²C EEPROM
- Optional Trusted Platform Module (TPM)

cPCI

- 66 MHz 64-bit PCI interface to J1 and J2
- PICMG 2.1 (Hot Swap support)
- PICMG 2.3 (PMC I/O to J3 and J5)
- PICMG 2.9 (dedicated IPMI controller)
- PICMG 2.16 (two 10/100/1000BASE-T Ethernet ports)

Front Panel

- Two RS-232/422/485 serial ports
- One or two Gigabit Ethernet ports
- General purpose LEDs

Back Panel

- Two RS-232/422/485 serial ports
- Two Gigabit Ethernet ports
- PMC I/O

Software Support

- Linux BSP
- Wind River VxWorks BSP
- Greens Hills INTEGRITY BSP
- QNX Neutrino BSP (contact factory)

Environmental Requirements

Contact factory for appropriate board configuration based on environmental requirements.

- Supported ruggedization levels (see chart below): 1, 3, 5
- Conformal coating available as an ordering option

Power Requirements

- Power will vary based on configuration and usage. Please consult factory.

Ruggedization Level	Level 1	Level 3	Level 5
Cooling Method	Standard Air-Cooled	Rugged Air-Cooled	Conduction-Cooled
Operating Temperature	0 to +55°C ambient (300 LFM)	-40 to +70°C (600 LFM)	-40 to +85°C (board rail surface)
Storage Temperature	-40 to +85°C ambient	-55 to +105°C ambient	-55 to +105°C ambient
Vibration	0.002 g ² /Hz, 5 to 2000 Hz	0.04 g ² /Hz (maximum), 5 to 2000 Hz	0.1 g ² /Hz (maximum), 5 to 2000 Hz
Shock	20 g, 11 ms sawtooth	30 g, 11 ms sawtooth	40 g, 11 ms sawtooth
Humidity	0% to 95% non-condensing	0% to 95% non-condensing	0% to 95% non-condensing

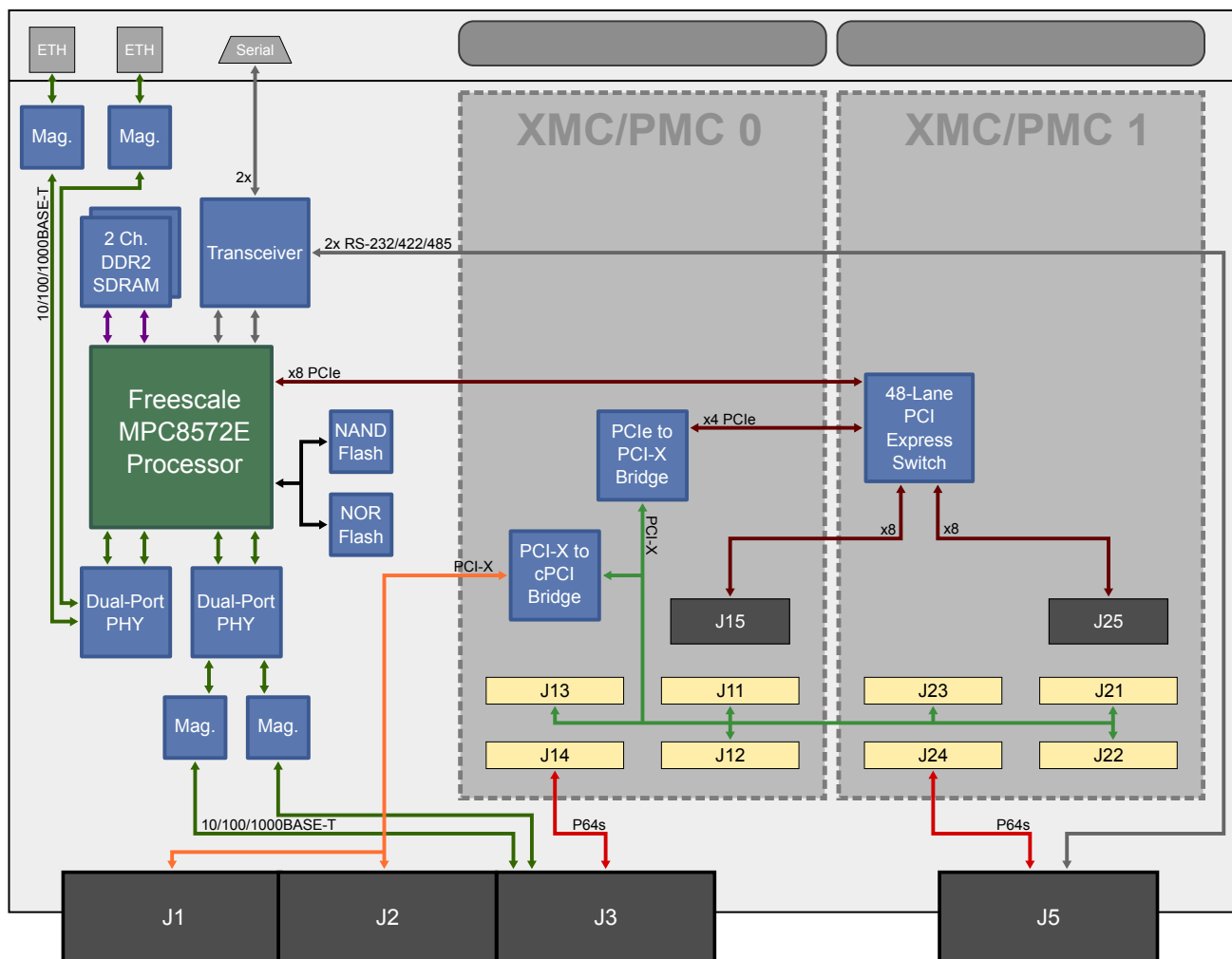

XCalibur1501

