



Fast, Flexible, and Customer-Focused Embedded Solutions

X-ES FPGA Development Kit

FPGA Development Kit Overview

- Supports the industry-standard AXI4 interface protocol
- Utilizes non-proprietary, industry-standard development tools
- IP blocks provided for all hardware interfaces and functions necessary to build complete FPGA designs
- Complete example designs included
- Includes software to configure, control, and communication with FPGAs
- Simplifies FPGA development and shortens time-to-market

FPGA Processing in Embedded Systems

In high-performance, real-time, embedded systems, FPGAs are typically employed in the critical data path. In a typical application, data streams into a system from sensors such as A/Ds, digital receivers, or video cameras, but the data rates of today's sensors can easily exceed a system's available communication and processor bandwidth. FPGAs can be incorporated into the system to address these issues. They are well suited to provide the sensor interface and to reduce the incoming streaming data to data rates that can be handled by the available communication and processor bandwidth.

FPGA Development Kit (FDK)

Extreme Engineering Solutions (X-ES) provides an FPGA Development Kit (FDK) to support the requirements of high-performance, real-time, embedded streaming data applications and to simplify the FPGA development process. The FDK is comprised of the Hardware Development Kit (HDK) and the Software Development Kit (SDK). The HDK includes the HDL code and files needed to build FPGA images, while the SDK includes drivers and utilities to set up, control, communicate with FPGAs.

The initial hardware supported by the FDK is the XPedite2400 XMC module. The XPedite2400 supports a Xilinx Virtex-7 FPGA (330T, 415T, 485T (standard), or 690T). In the X-ES FDK model, FPGAs and processors are interconnected via PCI Express links.

Hardware Development Kit (HDK)

Features

- Based on AXI4 interface protocol, all provided logic blocks support AXI4 interconnects
- Utilizes standard Xilinx and third-party tools – ISE, XPS, Mentor ModelSim
- Logic blocks provided for all external hardware interfaces
 - PCIe-to-AXI bridge (high-speed data transfer to a host PC)
 - External memory controller (access to onboard Flash for non-volatile storage)
 - DDR3 controller (general-purpose memory controller for onboard dynamic memory)
 - I²C (controls access to onboard EEPROM, Real-Time Clock (RTC), temperature sensors, and GPIO)
 - UART (provides serial port capability)
 - Input/output (support for DAC, ADC, etc.)
 - Additional masters and slaves (custom IP blocks can be added with AXI4 and PCIe access)
- MSI-X interrupt controller (supports inbound and outbound interrupts)
- Device ID block (provides a linked list of capabilities present in the FPGA that host software can parse through to determine at runtime the capabilities present in the FPGA)
- High-performance DMA controller
- Tandem/partial reconfiguration support available
- Complete example designs provided
- Complete documentation

The non-proprietary HDK is designed to simplify the process of FPGA development and provides a framework to easily integrate FPGA algorithms. Ease-of-use is facilitated through the support of the AXI4 interface protocol and use of the latest generation Xilinx ISE and EDK tools. Support for the AXI4 interface protocol makes logic blocks readily reusable, and the Xilinx EDK provides a GUI which enables logic blocks to be connected graphically by dragging and dropping them into a design.

All X-ES logic blocks interface to the AXI4 interconnect. Standardizing on the AXI4 interconnect enables logic blocks in the HDK from Xilinx and other third parties to be used without modification, unlike other FPGA development environments that require modifications to the HDL code in order to create a working FPGA design.

AXI4 includes three interconnect protocols that support both memory-mapped and streaming type interfaces:

- AXI4: A traditional single-address burst interconnect supporting up to 256 data beats per burst (system-dependent width)
- AXI4-Lite: A subset of the AXI4 protocol that only sends one data word per transaction
- AXI4-Stream: A data-streaming interconnect that supports unidirectional, high-speed data transfers

The HDK includes example FPGA designs and pre-built FPGA images (.bit files). The use of Xilinx ISE and XPS (EDK) project in the example designs highlights the ability for quick and easy reconfiguration of the example designs to incorporate customer logic.

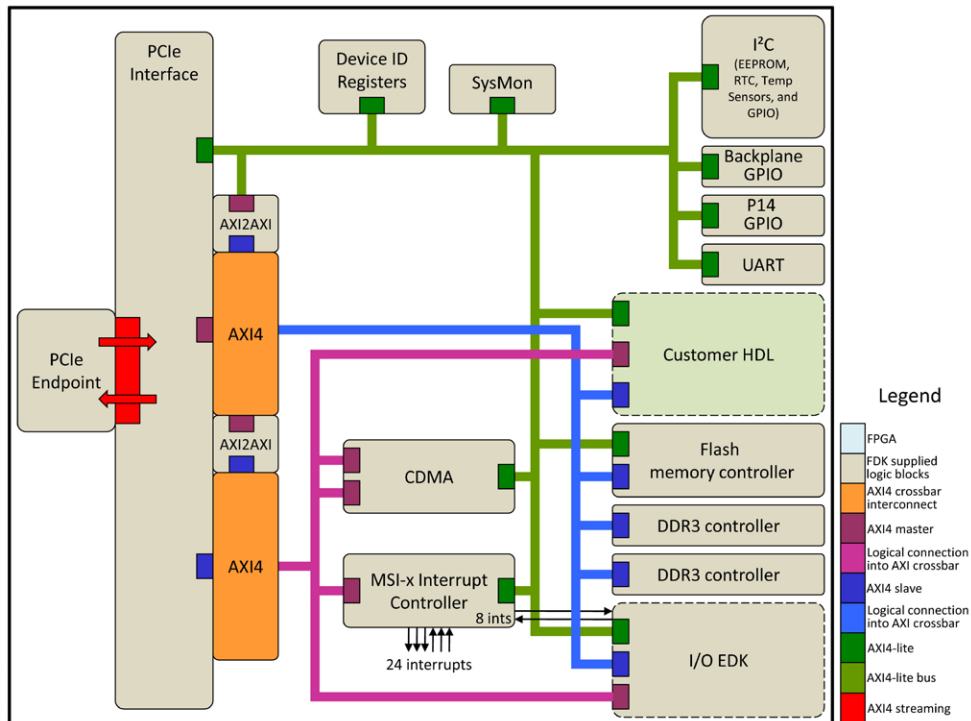

Figure 1: FPGA Block Diagram

Software Development Kit (SDK)

Features

- Drivers to communicate with FPGA devices
- Utility and APIs to re-flash and set up FPGA
- APIs to discover capabilities loaded into FPGA
- Support for VxWorks and Linux on both Freescale (QorIQ) and Intel® (Core™ i7) processors

The Software Development Kit (SDK) includes drivers, libraries, and utilities to support the control of and communication with FPGAs in the system.

A driver framework is provided for software developers. The provided FPGA driver queries the FPGA to determine the capabilities that are instantiated in the FPGA. Based on the FPGA capabilities it discovers, the FPGA driver loads capabilities drivers. X-ES provides capability drivers for the following FPGA capabilities.

- I²C
- GPIO
- RS-232
- Flash
- Daughter card interfaces (ADC and DAC)

These drivers can be used as is or as a starting point for software developers to create their own application. Customers can add additional capability drivers.

All SDK software is written in ANSI C. Source code is provided for SDK software. The SDK is supported on Linux running on Intel and Freescale hosts.



Figure 2: XPedite2400

FPGA Tools

Xilinx ISE Design Suite 14.5+

Mentor Questa 10.x+

Glossary

AXI4	Industry-standard interface for connecting logic blocks
HDL code	Language for describing how to utilize the resources within an FPGA
Logic block	FPGA logic created by "compiling" HDL code via the ISE; sometimes referred to as IP, IP blocks, or firmware

Corporate Overview

Extreme Engineering Solutions, Inc. (X-ES), a 100% U.S.A.-based company, designs and builds single board computers, I/O boards, power supplies, backplanes, chassis, and system-level solutions for embedded computing customers. X-ES offers cutting-edge performance and flexibility in design, plus an unparalleled level of customer support and service. For further information on X-ES products or services, please visit our website: www.xes-inc.com or call (608) 833-1155.

